

Pilot's Guide

Engine Data Management

EDM-930

Primary

TSO

Copyright © 2010 J.P. Instruments, Inc.
All Rights Reserved

J.P. INSTRUMENTS INC.

Information: P. O. Box 7033

Huntington Beach, CA 92646

Factory: 3185 B Airway

Costa Mesa, CA 92626

(714) 557-5434 Fax (714) 557-9840

www.jp instruments.com

Printed in the United States of America

Rev I 10-12

Last printed 5/14/2013 9:17:00 AM

Table of Contents

Section 1 - Getting Started	1
Display View Angle	2
List of abbreviations and acronyms	3
Fuel Flow Computer Basics	3
Control Button Basics	4
Display Screen Basics	4
Remote Auxiliary Display Basics	5
RPM and MAP Display Basics	5
Linear Bar Graph Display Basics	5
Scanner® Display Basics	6
LeanFind Basics	6
Section 2 - Interpreting Data	7
Operation for each Phase of Flight	7
Typical Normal Measurements	9
Section 3 - Displays and Controls	12
Control Buttons	12
RPM and MAP Displays	14
Scanner Displays	14
Remote Auxiliary Display	17
Hobbs Display	17
Dimming the Display	17
Section 4 - Operating Modes	18
Automatic Mode	18
Manual Mode	19
Section 5 - LeanFind	20
LeanFind Procedure—General Explanation	24
Expanded Leaning Procedures	28
Section 6 - Fuel Flow Operation	29
Fuel Management	29
Start Up Fuel	30
Resetting ‘USD’	32
Resetting ‘USD’	33
Resetting ‘USD’	34
Trip Mode (Accumulate Trip Totalizer)	34
Scanner Fuel Flow Display Select	34
Section 7 - Alarms	35
Non-primary Alarm Priority	35
Section 8 - Memory and Data Download	36
Downloading Data from the EDM	37
Transferring data from the USB Flash Drive to a PC	37

Section 9 -	First Time Setup and Customization	38
	Pilot Programming Mode	40
	Adjusting the HP Constant for Rich of Peak Operation	42
	Adjusting the MAP	42
	Adjusting the HP Value	43
	Fuel Flow K factor	43
	Programming Trip Mode	45
	Setting the GPS Com Format	46
Section 10 -	Custom Key Card	46
Section 11 -	Setting Fuel Calibration Points	47
	Getting Started...Collecting Fuel Level Calibration Data using the EDM as a meter.	48
	After you have collected your data...Entering / Editing Fuel Level Calibration Data	49
	Troubleshooting the EDM	52
	Troubleshooting the EDM	53
	Diagnostic Testing on Startup and During Flight	53
	Diagnostic Messages	54
Section 12 -	Appendices	56
	TSO-only differences from Primary Instruments	56
	Shock Cooling	57
	Rear Apron Connector Locations	58
	Connector pin assignments	58
	Connector pin assignments	59
	Navigation Data Formats	60
	Navigation Data Ports for GPS Comm	60
	Interface connections to selected GPS models	60
Section 13 -	Technical Support	61
	Index	62
	<u>QUICK REFERENCE</u>	66

EDM-930 SYSTEM DISPLAYS



EDM-930 Main display



Remote Auxiliary Display (RAD)

Product Features

- Hands-free, automatic scanning
- LeanFind™ finds the first and last cylinder to peak with true peak detect—eliminates false peaks
- Displays both leaned temperature below peak and peak
- Battery voltage with alarm
- Amperes (load or charge/discharge meter)
- Programmable alarm limits
- Exhaust Gas Temperatures (EGTs) to stable 1°F resolution
- DIF low to high EGT with alarm
- Shock cooling monitored on *every* cylinder
- Fast response probes
- Non-volatile long term memory
- Records and stores data up to 30 hours
- Post-flight data retrieval
- Data retrieval software
- Oil pressure
- Oil temperature
- Turbine inlet temperature, if applicable (optional)
- Outside air temperature
- Compressor discharge temperature (optional)
- Carburetor temperature or induction temperature (optional)
- Fuel pressure, if applicable
- Fuel level Voltage, Resistive or Capacitive (frequency)
- Fuel Flow
 - Solid-state rotor fuel flow transducer
 - Fuel quantity in gallons, kilograms, liters, or pounds
 - Low fuel quantity alarm
 - Low fuel time alarm
 - GPS interface
 - Instantaneous fuel flow rate
 - Total amount of fuel consumed
 - Total fuel remaining
 - Time to empty at the current fuel flow rate
- RPM and manifold pressure
- Automatically calculates percent horsepower
- Hobbs® timer
- Remote Auxiliary Display (RAD)

Section 1 - Getting Started

Important Note!

You ***must*** have the remote auxiliary display—RAD— installed on the instrument panel of your aircraft. This is required for FAA certification of the EDM-930 as a primary instrument. Upon start up, the RAD displays the make and model of you aircraft, which must be verified before you can rely on the EDM-930 for use as the primary engine instrument cluster. The RAD also will continuously notify you of any alarm conditions, regardless of whether you have cleared them on the EDM-930 display.

This is not an option!

This is a summary of basic operation. Detailed descriptions of all operations appear later in this Pilot's Guide.

EDM-930 primary instruments have preset alarm limits and cautionary ranges (user cannot change them) typically for the following measurements: oil temperature, oil pressure, fuel pressure, fuel quantity, cylinder head temperature, turbine inlet temperature, manifold pressure, and RPM. Your EDM-930 contains a custom Key Card. For Primary configurations, the Key Card activates the primary engine instrument abilities of your engine monitor.

Note: Fuel quantity gauges must be calibrated to the aircraft and will not be functional until the fuel calibration process has been performed.

Display View Angle

The best view angle for the pilot is in the horizontal mode with the buttons on the bottom. The best Portrait mode is with the buttons on the right.

View angles are per the table below:

Viewing angle	Horizontal	Left	65 Degrees
		Right	65 Degrees
	Vertical	Up	50 Degrees
		Down	60 Degrees

List of abbreviations and acronyms

Gauge Function	Message Area Alarm Abbreviation
Primary	Primary
Engine rotational speed	RPM xxxx
Engine Manifold Pressure	MAP xx.x in hg
Engine Cylinder Head Temp	CHT2 xxx °F
Engine Oil Temperature	O-T xxx °F
Engine Oil Pressure	O-P xxx °F
Fuel Pressure	F-P xx PSI
Fuel Flow to engine	F-F xx.x GPH
Comp. Discharge Temp.	CDT xxx °F
Turbine inlet Temp. Left side	TIT-L xxxx °F
Turbine Inlet Temp. Right side	TIT-R xxxx °F
Single Turbine Inlet Temp.	TIT xxxx °F
Non-Primary	Non-Primary
Exhaust Gas Temp.	EGT2 xxxx °F
Shock Cooling of CHT	CLD xx °/MIN
Differential Temp. of EGT	DIF xx °F
Bus Voltage	Volts xx.x
Amperage Load	AMPS xx
Outside Air Temp.	OAT xx °F
Estimated Time to Empty	Est. T to E xx:xx H:M
Fuel used to date	USED xx.x GAL
Estimated Remaining fuel	Est. REM xx GAL
Estimated Fuel required to Waypoint	Est. WP REQ xx GAL
Estimated Fuel Remaining at Waypoint	Est. WP RES xx GAL
Nautical Miles per Gallon	ECON xx.x MPG
Brightness, Dim control	DIM/BRT

Fuel Flow Computer Basics

The fuel flow computer tracks the fuel flowing to the engine and computes various values based on this. At installation, then each time you refuel the aircraft, you must inform the EDM about how much useable fuel is onboard. This is

done via the *REFUEL* function. There are three ‘Quickset’ ways to do this:

1. **Main 74.0 GAL:** MAIN tanks are filled (no other fuel onboard).
2. **Main + Aux 94.0 GAL:** MAIN +AUX tanks are filled.

3. **Adjust? 0.0 GAL:** Partial fuel added to existing quantity.

See page 29 for expanded information on the refueling process.

Control Button Basics

Four operating buttons control all functions of the EDM. These buttons change labels depending on the current state of the EDM..

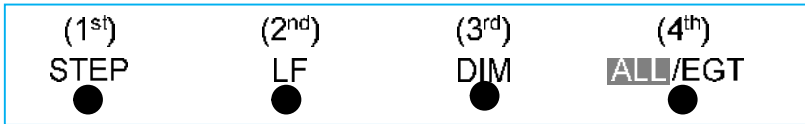

The term *tap* is used to denote pressing a button momentarily. The term *hold* is used to denote pressing and holding a button for five seconds or longer.

Display Screen Basics

The display screen is arranged into three sections. The top left is the *RPM* and *MAP* section. The bottom left is the *Scanner®* section. And the right side is the *Linear Bar Graphs* section. The instrument ranges and alarm limits are configured to match those of your aircraft when the EDM is set up as a Primary instrument.

Remote Auxiliary Display Basics

The Remote Alarm Display 'RAD' provides alarm display, RPM and MAP, and is located directly in front of the pilot. Upon power up, the RAD shows the Aircraft model, engine type and declares instrument status: 'Primary' (if applicable). Before each flight, confirm that it matches your aircraft requirements.



RPM and MAP Display Basics

The upper half shows the RPM (Revolutions per Minute) and the lower half shows the MAP (Manifold Pressure). Operations exceeding red line cause the digital value to turn red.

Percent horsepower is displayed digitally below and to the left of the MAP arc.



Linear Bar Graph Display Basics

The Bar Graphs section contains nine dedicated bar graphs with digital display organized in a three by three matrix. An example is shown here. Pointers move up and down in response to value changes and digital readouts turn red when exceedances occur.

Note: functions displayed in this example may differ from your EDM.

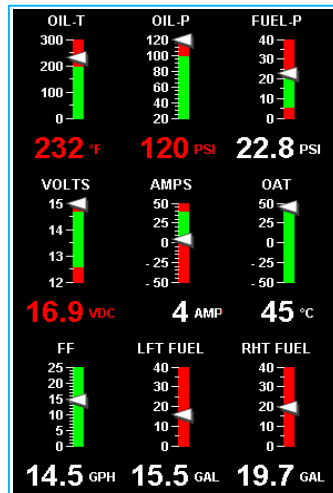

Scanner® Display Basics

The EDM Scanner section is located in the lower left area of the screen. It consists of a graphical display of EGT and CHT (and TIT if so equipped) and a digital display that automatically scans the various parameters. You can select Manual Mode by tapping STEP to lock onto the parameter of interest. To return to Automatic scan mode, tap LF followed by tapping STEP.

LeanFind Basics

Simply pre-lean, then tap the **LF** button (Lean Find) and begin leaning. The EDM will assist you in finding the first cylinder to peak. This example is for Rich of Peak. See page 20 for a more detailed description of leaning.

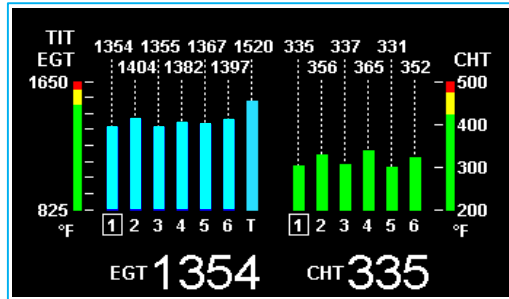

1. Establish cruise at approximately 65 to 75% power and pre-lean the mixture to 50°F estimated rich of peak EGT on any cylinder.
2. Wait about 30 seconds, then tap the **LF** button.
3. Begin leaning the mixture smoothly *without stopping*. Turn a vernier about ¼ turn per second; retract a non-vernier or quadrant lever so that EGT rises about 10°F per second.
4. Stop leaning when you see **LEANEST** for two seconds, followed by—for example—^{EGT}1520 ^{FF}13.8. The left number is the current temperature of the first EGT to peak and the right number is the current fuel flow.
5. Now tap the **PEAK** button to display the EGT difference from peak which is very useful for setting desired degrees below peak. *Note: The value for EGT ROP will be a negative value which means you've gone lean of peak by the time you stopped leaning the mixture.*
6. Slowly enrich the mixture noting that the EGT difference diminishes as EGT climbs back to peak, followed by it going positive again. Stop enriching at the desired EGT difference (such as 'EGT 75').
Note: Please refer to the engine manufacturer's operating guide for

the correct value for EGT difference rich of peak operation at 75% and 65%

7. You can also see what the peak EGT was by holding the **PEAK** button.
8. Tap **STEP** to exit the Lean Find Mode.

Section 2 - Interpreting Data

Operation for each Phase of Flight

(worth adding to your run-up checklist)

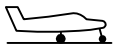

Engine Run-Up

Suggested setup:

- Set engine to run-up RPM

Normalize view:

- Manual mode

Verify:

- uniform rise of about 50°F in all EGTs in single magneto operation.
- uniform rise of EGTs with application of the mixture control.

Be alert for:

- unusually low voltage (less than nominal battery voltage)
- cold OIL and normal oil pressure
- abnormally high CHT
- large drop in EGT on one cylinder in single magneto operation—may be fouled spark plug.

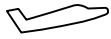

Take-Off, Climb, and Full Throttle Operations

Suggested setup:

- Standard view
- Automatic mode

Verify:

- EGTs and CHTs consistent with past climbs. EGTs should be in the 1100 to 1300°F range (100° to 300°F cooler than cruise) due to fuel cooling.

Be alert for:

- high EGT in one cylinder, 300°F above the others may indicate plugged injector or leaking manifold gasket on a carbureted engine. At high density altitude an overly rich mixture can significantly reduce engine power.
- If all EGT columns go off scale to the top of the column, be sure you are not in Normalize view, as indicated by the symbol NRM above the Scanner® section.



Cruise

After the engine is warmed up, use LeanFind to lean the mixture.

Suggested setup:

- Normalize view
- Automatic mode

Be alert for:

- uneven EGTs (injected engines). Make fine adjustments to throttle, then RPM, then mixture to level the display columns.
- abnormal patterns of EGTs and CHT. (see *Engine Diagnosis Chart* on page 10).

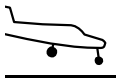

Descent

Suggested setup:

- Standard view
- Manual mode

Be alert for:

- CLD: shock cooling alarm is set to -60°F. Average cool rates of -40°F/minute to -50°F/minute are normal, depending on the engine size.

Typical Normal Measurements





The following chart lists typical *normal* measurement values that you will observe for most general aircraft engines. Your particular engine's ranges may not fall within these values.



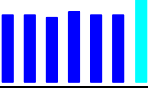
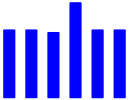
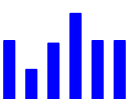
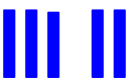
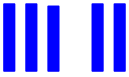
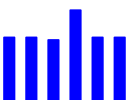

<i>Measurement</i>	<i>Normal range</i>	<i>Comments</i>
EGTs in Cruise	1350°F 1550°F	<ul style="list-style-type: none"> • under 200 HP engines • high performance engines • (EGT should drop 200°F when full throttle is applied)
EGT span (DIF)	70 to 90°F 120 to 150°F	<ul style="list-style-type: none"> • fuel injected engines • carbureted engines
TIT	1600°F average	<ul style="list-style-type: none"> • 100° higher than EGT
CHTs	350°F (OAT 60°F) 410°F	<ul style="list-style-type: none"> • normally aspirated engines • Turbocharged engines
CHT span	50 to 70°F	<ul style="list-style-type: none"> • 100° with gasket probes
OIL T	200°F	<ul style="list-style-type: none"> • oil cooler thermostat typically opens at 180°F
OIL P	30 to 60 psi	<ul style="list-style-type: none"> • varies with aircraft type
FUEL P (injected)	14 to 18 psi	<ul style="list-style-type: none"> • varies with aircraft type
FUEL P (carbureted)	0.5 to 8 psi	
Shock cooling*	-40°/minute -55°/minute -200°/minute	<ul style="list-style-type: none"> • tightly cowled engines • Bonanza • helicopter

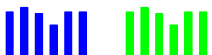
* Maintain a cooling rate magnitude of less than -50°/minute. You will find that the cylinder with the greatest shock cooling may shift from front cylinders (during climb out) to the rear cylinders (during descent).

Engine Diagnosis Chart

The following chart will help you diagnose engine problems in your aircraft.

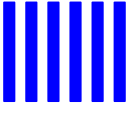
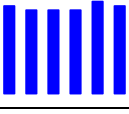
<i>Display</i>	<i>Symptom</i>	<i>Probable Cause</i>	<i>Recommended Action</i>
	TIT ~100° higher than EGTs	This is normal	
	75° to 100° EGT rise for one cylinder during flight	Spark plug not firing due to fouling, faulty plug, wire or distributor.	Enrich mixture to return EGT to normal. Have plugs checked.
	EGT Increase or decrease after ignition maintenance	Improper timing: high EGT → retarded ignition; low EGT → advanced ignition.	Check EGT for each magneto to determine any uneven timing.
	Loss of EGT for one cylinder. Engine rough	Stuck valve. Other cylinders are okay.	Have valve train checked.
	Loss of EGT for one cylinder; <i>no digital EGT</i>	Failed probe or failed wire harness.	Swap probes to determine if probe or wire harness is bad.
	Decrease in EGT for one cylinder	Intake valve not opening fully; faulty valve lifter.	Have valve lifter or rocker arm checked.
	Increase in DIF at low RPM	Low compression (blow by) in cylinder	Check compression.
	EGT and CHT not uniform	Normal for carbureted engines. Dirty fuel injectors or fouled plugs.	Check injectors and plugs.
	Decrease in EGT for all cylinders	Decrease in airflow into the induction system. Carb or induction ice.	Check for change in manifold pressure.

<i>Display</i>	<i>Symptom</i>	<i>Probable Cause</i>	<i>Recommended Action</i>
	Slow rise in EGT. Low CHT	Burned exhaust valve. CHT is low due to low power output.	Have compression checked.
	High CHT on cylinders on one side of engine	Obstruction under cowling.	Check for improper installed baffling, cowl flap misalignment or bird nests.
	Rapid rise in CHT of one cylinder	Detonation.	Reduce power.
	Sudden off scale rise for any or all cylinders	Pre-ignition Normalize view or failed probe	Full rich and reduce power. Change to Standard view Check probe
(no picture)	Loss of peak EGT	Poor ignition or vapor in fuel injection system.	Have magneto tested.
(no picture)	Decrease in peak or flat EGT response to leaning process	Detonation. Usually the result of 80 Octane fuel in 100 Octane engine.	Enrich mixture, reduce power and relean mixture. Repeat to find power setting where normal peak is obtained or run rich.
	Below 10,000 ft. full throttle causes EGTs to rise	Weak or defective mechanical fuel pump.	Apply booster pump. If EGTs drop, replace fuel pump.
	CHT more than 500°, EGT normal. Adjacent EGT may be low	Leaking exhaust gasket blowing on CHT probe.	Look for white powder around cylinder to determine leak area.

Section 3 - Displays and Controls

The EDM monitors engine temperatures, pressures and voltages, assists in adjusting the fuel/air mixture, and helps diagnose engine malfunctions. There are multiple components of the user interface:

- Four front panel operating buttons below the bottom of the display.
- RPM and MAP display in the upper left corner of the display
- Scanner analog display including cylinder number and index square in the lower left corner of the display
- Scanner digital display for numeric readouts and messages at the bottom left
- Bar graph displays on the right half of the display

Control Buttons

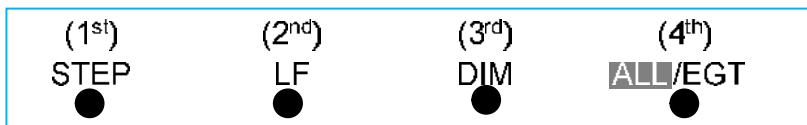

Four operating buttons control all functions of the EDM. These buttons may change labels depending on the current operating mode of the EDM. The term *tap* is used to denote pressing a button momentarily. The term *hold* is used to denote pressing and holding a button for five seconds or longer. Button layout is shown below:

1st Button

- In the Automatic mode, *tapping* the **STEP** button stops Scanner auto-sequencing and changes to Manual mode. Each *tap* of the **STEP** button then displays the next measurement in the sequence. Holding the **STEP** button sequences in reverse order.
- In the LeanFind mode tapping the **EXIT** button will terminate the LeanFind mode and change to the Automatic mode.
- In the Program mode tapping the **NEXT** button will advance to the next item.

2nd Button

- In Automatic or Manual modes, tapping the **LF** button will activate the LeanFind mode.
- In the LF mode holding the **LF** button after peak EGT is found will display the peak EGT.
- In Automatic or Manual modes holding the **LF** button for three seconds will toggle between Standard and Normalize (NRM) views.
- In the programming mode, tapping the **PLUS** or **MINUS** button will allow you to edit a parameter value.
- Holding **LF** during power up will display the primary alarm limits after the self-test is complete.

1st and 2nd Buttons

- Holding both the **STEP** and **LF** buttons simultaneously for five seconds will enter the pilot programming mode.
- Just after entering Lean Find Mode (but before any EGT has risen), holding both First and Second buttons for five seconds will toggle between LOP or ROP leaning modes.
- Tapping both the **STEP** and **LF** buttons simultaneously in Manual mode toggles to 'include' or 'exclude' the displayed non-primary measurement from the Automatic mode. Note: Measurements are never excluded from the Manual mode.

3rd Button

- Tapping **DIM** (brightness decreases) or holding **DIM** (brightness increases) allows decrease or increase brightness respectively.

2nd and 3rd Buttons

- Holding both the **LF** and **DIM** buttons simultaneously will display the Hobbs readings. Tap button labeled **NEXT** to see additional information screens.

4th Button (ALL/EGT/FF)

- Select what is shown during Scanner auto-sequence. Choices are **ALL**, **EGT** or **FF**. Highlighted one is what is active.

RPM and MAP Displays

The upper left side of the display shows RPM above the MAP. The arcs represent the analog values. Percent horsepower is shown to the lower left of MAP.



Scanner Displays

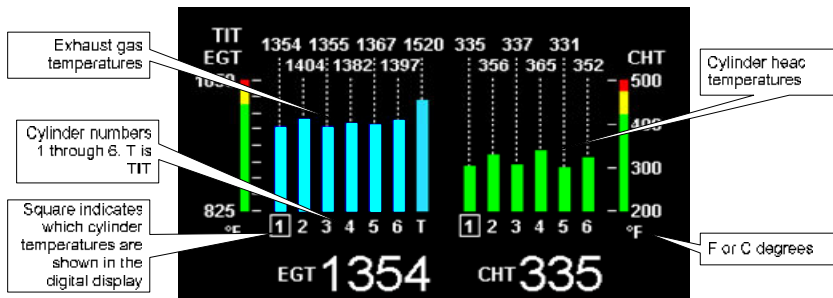

Scanner EGT and CHT Analog Bar Graph

The height of each column represents a EGT or CHT or TIT (if installed) temperature. The graph resolution depends on the programmed span between the top and bottom of the range marks. Note: when in certain modes, such as leaning or normalize, the EGT resolution will temporarily be finer.

Cylinder Numbers and Index

Just below the bar graph columns are numbers identifying the respective cylinder. If TIT is installed, it is labeled by the letter **T** underneath. A square 'Cylinder I.D. Index' surrounding a number indicates what cylinder is currently selected and relates to the digital display.

Scanner Digital Display

Located under the Scanner bar graph area is the alphanumeric display. It displays alphanumeric values for different parameters as well as status and alarm messages.

Normalize / Standard View

To toggle between Standard and the Normalize views, hold the **LF** button for three seconds until the **NRM** icon toggles on or off. Note: Normalize cannot be activated while in Lean Find mode.

- **Standard view** (when the **NRM** icon is *not* lighted): the EGT represent absolute temperature. The top of the columns indicate absolute temperature relative to the adjacent range mark temperature scale. A maximum height column depicts the temperature at the top of the range mark scale (or more), while no column represents the temperature at bottom of the range mark scale(or less). The *Standard view* permits comparison of EGTs *across all* cylinders.
- **Normalize view** (when the **NRM** icon is lighted): the EGT represent the difference in temperature from the mid-point of the range mark scale. When you change to the Normalize view, all EGT columns are initially normalized to the mid-point for deviation trend analysis. Any changes are shown as an increase or decrease relative to the mid-point, thus giving an instantaneous indication that an EGT has deviated. You normally use normalize in level cruise, but it is also useful during steady state run-ups. Note: A common misapplication is to be in the Normalize view and then change power setting. This causes all columns to go off scale, high or low. Select Standard view before changing power or altitude.

Temperature Units (°F or °C)

The EDM can display engine temps in either **°F** or **°C** (Fahrenheit or Celsius). In Primary configurations, this is set to the same units as the configuration the aircraft was originally certified to.

Linear Bar Graph Displays

The linear bar graphs are arranged in a three by three matrix on the right half of the display. A typical layout is depicted here (Note: your actual configuration may vary). Typical functions that can be displayed are:

- Oil temperature
- Oil pressure
- Fuel pressure
- Bus voltage
- Amps (charge/discharge shown)
- OAT
- Fuel flow
- Left tank fuel quantity *
- Right tank fuel quantity *

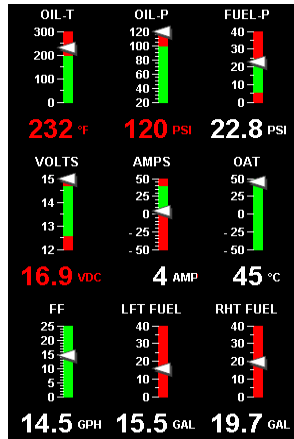

* The fuel quantity gauges will not be functional until the fuel calibration process has been completed.

The range of the bar graphs depends on the programming. Range, redlines and/or limits are typically set to match the original aircrafts gauge markings. These are locked for Primary installations, however non-primary gauges can be user modified, using 'EDM Config' which is currently available through the front panel buttons. Editing of Gauge Layout requires EDM Software version 1.20.489 or later. Note: Amps can operate either as a charge/discharge or load meter, depending on programming. For charge/discharge, the center of the bar is zero and the top and bottom are maximum charge and discharge, respectively.

Remote Auxiliary Display

See the important note on page 1 regarding the RAD.

The remote auxiliary display '**RAD**' provides redundancy and allows positioning a smaller display directly in front of the pilot. Upon power up the RAD displays the EDM's programmed configuration (aircraft make and model and primary status). Confirm that it matches your aircraft configuration before using the instrument. This auxiliary display will normally show RPM and MAP, but will display a blinking alarm message, duplicating the alarm indication of the EDM. For example, low calculated fuel remaining of 7.7 gallons would show:



??	REM
----	-----

Hobbs Display

Holding both the **LF** and **DIM** buttons simultaneously will display the Hobbs times similar to the example below:

HOBBS Times

EDM HOBBS:	127.4
Engine HOBBS:	120.6
Flight HOBBS:	2.7
Flight Duration:	02:42:21

Dimming the Display

Automatic dimming is provided to dim both the panel display and the remote alarm display. You can manually adjust brightness by tapping (decrease brightness) or holding (increase brightness) the **DIM** button.

Section 4 - Operating Modes

The EDM has four basic operating modes: *Automatic*, *Manual*, *Program* and *LeanFind*. *LeanFind* is described in the next section; *Program* mode is described on page 38, 'First Time Setup and Customization'. When you first turn on the power the EDM starts in the *Manual* mode, but will enter the *Automatic* mode after a few minutes. The *Automatic* mode provides you with engine monitoring information for the majority of flight conditions. To optimize the mixture, use the *LeanFind* mode. To display specific parameters, use the *Manual* mode. In either *Automatic* or *Manual* modes, the display always shows the Scanner bar graphs for EGT and CHT for each cylinder and TIT (if so equipped).

Automatic Mode

To activate Automatic Scanner Mode, just tap the LF button, then tap the STEP button. In the *Automatic* mode the EDM changes which measurement is displayed every four seconds (factory default is 'Auto Scan Rate 4'), however you can change this rate in the *Program* Mode. A setting of zero disables auto scanning altogether.

Some non-primary measurements can be excluded from the *Automatic mode*: tap STEP to enter the *Manual* mode. Tap STEP repeatedly to index to the measurement you want to exclude. Then tap both the STEP and LF buttons simultaneously. Excluded measurements display a decimal point before the measurement name. For example:

Included: 1540 CDT Excluded: 1540 •CDT

Tapping the STEP and LF buttons simultaneously will toggle back and forth between *include* and *exclude*. Note: All measurements are always checked for alarm conditions every second.

- Every time you turn on the EDM, all measurements are reset to be *included*.
- All installed measurements are always displayed in the *Manual* mode. Exclusion only applies to the *Automatic* mode.

Manual Mode

To activate Manual Mode, just tap the **STEP** button. Use the Manual mode when you want to lock on one specific measurement such as shock cooling during descent, or your hottest CHT during climbs. To select the desired parameter, tap the STEP button until it appears. To return to the Automatic mode, tap the LF button and then tap the STEP button. You may completely disable the Automatic mode by setting zero for 'Auto Scan Rate 4'. See Pilot Programming.

Scan Sequence Example

<i>Measurement</i>	<i>EXAMPLE</i>	<i>COMMENTS</i>
EGT, CHT	EGT 1354 CHT 335	Square indicates the cylinder being viewed
TIT	1370 TIT	Turbine Inlet Temperature # 1
Shock Cooling	-30 CLD	Square indicates fastest cooling cylinder
Compressor Discharge Temperature	300 CDT	Temperature into intercooler
Induction Air Temperature	125 IAT	Temperature out of the intercooler
Carburetor Temperature	-22 CRB	(Not available when CDT is installed)
Difference between hottest and coldest EGT	80 DIF	Square indicates most widely deviating cylinder
Fuel Remaining	^{Calculated} 37.2 REM	In gallons, liters, pounds or kilograms
Fuel required to next GPS WPT or Destination	25.9 REQ	Present with GPS interface, valid signal and way point
Fuel Reserve at next GPS WPT or Destination	^{Calculated} 11.3 RES	Present with GPS interface, valid signal and way point
Nautical Miles per Gal	13.0 MPG	Present with GPS interface and valid signal. MPK, MPL, MPP for dif units
Time to Empty	^{Calculated} 02:45 H:M	Hours: minutes calculated remaining at current fuel burn.
Total Fuel Used	38 USD	Since last refueling or trip total.

Section 5 - LeanFind

The EDM supports two methods of leaning; **ROP** (Rich Of Peak) and **LOP** (Lean Of Peak). Note: on power-up, the unit defaults to Rich Of Peak mode, but is easily changed to Lean Of Peak mode. During traditional Rich Of Peak leaning, you'll finalize the mixture to about 20° to 80° rich of peak (depending on engine operating requirements). However, with the advent of closely balanced injectors (such as GAMI), it is possible to set the mixture lean of peak—thus saving fuel and running the engine cooler. Both Rich Of Peak and Lean Of Peak processes are described in detail in this manual.

Upon reaching cruise configuration, use the LeanFind mode to identify the correct cylinder to reach peak EGT (for Rich Of Peak this is the **FIRST** to peak, for Lean Of Peak this is the **LAST** to peak). To change from one method to the other, right after activating LeanFind, hold **STEP** and **LF** and the other method will be momentarily shown: **ROP** (Rich Of Peak) or **LOP** (Lean Of Peak). Release buttons after the other method appears.

The illustration below shows the various relationships between the mixture, fuel flow and engine power:

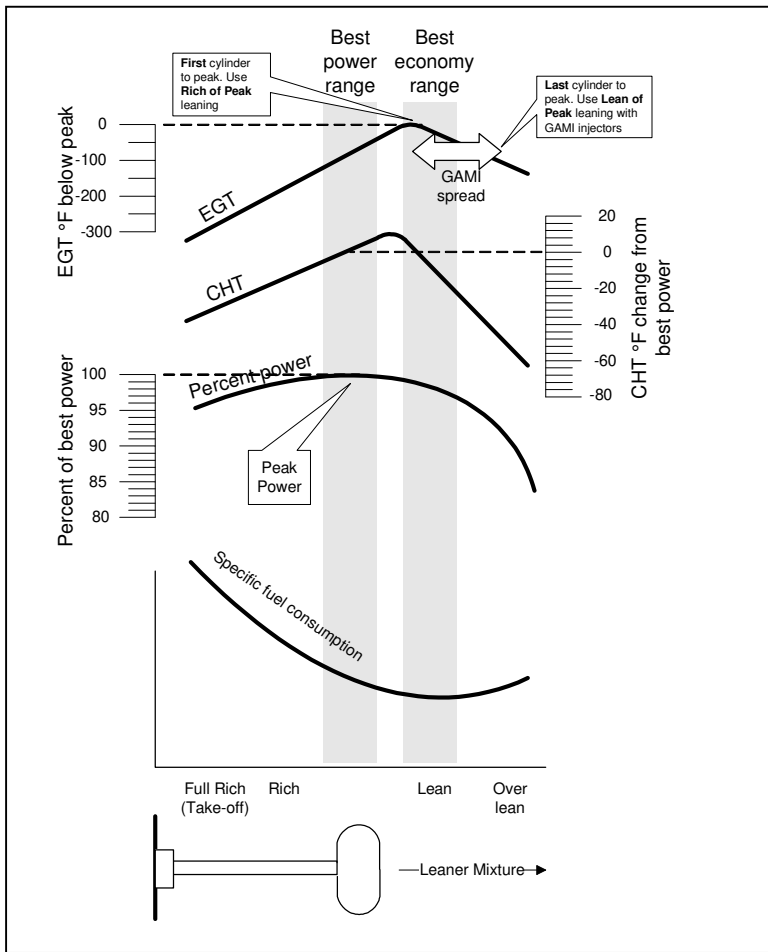

The following pages provide step by step guidelines in leaning your engine, for both rich of peak and lean of peak modes:

Rich of Peak leaning is as simple as:

- A. Pre-lean your mixture.
- B. Tap the LF button (verify *ROP* appears).
- C. Lean mixture until *LEANEST* flashes (peak found).
- D. Enrichen to the desired value 'Rich Of Peak'.

R	Procedure	Scanner Example	Comments
1	Establish cruise at 65 to 75% power.		
2	Pre-lean the mixture to 50°F estimated rich of peak on any EGT: _____°F.	EGT <i>1490</i> CHT <i>370</i>	* See 'Pre-leaning'
3	Wait one minute		Let engine stabilize.
4	Tap the LF button	ROP	Start LeanFind (if <i>LOP</i> appears hold STEP & LF until <i>ROP</i> appears)
5	Lean the mixture at approx. 10°/second <i>without</i> pausing.	EGT <i>1520</i> FF <i>13.8</i>	Flashing cylinder I.D. box identifies that EGT increased at least 15°F. EDM is now looking for first EGT to peak.
6	Stop leaning when a column begins flashing. You will see <i>LEANEST</i> for one second, followed by:	EGT <i>1545</i> FF <i>12.4</i>	Flashing cylinder I.D. box <i>AND</i> its column indicates leanest cylinder. Due to thermal inertia this will usually be about -15°F down the lean side of peak.
7	If you hold PEAK, the values of EGT and FF when peak was found are displayed.	EGT ↑ <i>1560</i> FF <i>12.9</i>	Captured peak EGT value and peak FF are displayed.
8	If you tap PEAK, the difference from peak EGT is shown. Tap again to return to the peaked EGT value.	EGT Δ <i>-90</i> FF <i>13.4</i>	A useful mode for setting mixture the desired degrees rich of peak - no math required! NOTE: Unit remembers view last used.
9	Slowly enrich the mixture noting that EGT is returning to peak. Stop enriching at the desired EGT. 'Peak': best Econ. 'ROP' target: best power.	EGT <i>1560</i> FF <i>12.9</i> EGT <i>1460</i> FF <i>13.6</i> (100° RICH OF PEAK)	

Lean of Peak leaning is as simple as:

- A. Pre-lean your mixture.
- B. Tap the LF button (verify *LOP* appears).
- C. Lean mixture until *RICHEST* flashes (peak found).
- D. Enrichen to the desired value 'Lean Of Peak'.

L	Procedure	Scanner Example	Comments
1	Establish cruise at 65 to 75% power.		
2	Pre-lean the mixture to 50°F estimated rich of peak on any EGT: _____ °F.	EGT <i>1490</i> CHT <i>370</i>	* See 'Pre-leaning'
3	Wait one minute		Let engine stabilize.
4	Tap the LF button	LOP	Start LeanFind (if <i>ROP</i> appears, hold STEP & LF until <i>LOP</i> appears)
5	Lean the mixture at approx. 10°/second <i>without</i> pausing. (cylinder I.D. box flashes when a EGT rises 15°F)	EGT <i>1520</i> FF <i>13.8</i>	Flashing cylinder I.D. box identifies the hottest EGT and that an EGT has increased at least 15°F which arms the EDM to now look for first EGT to peak.
6	After the first EGT peaks, you will see LEANEST for one second and bars coming from the top down. Continue leaning.	EGTΔ <i>-17</i> FF <i>12.4</i>	When bars come from the top down, the cylinder I.D. box identifies the first EGT that peaked (leanest). Continue leaning.
7	When RICHEST appears, fine tune the delta EGT to the desired degrees below 'Peak' (Lean of peak).	EGTΔ <i>-45</i> FF <i>11.6</i>	
8	If you hold PEAK, the peak EGT recorded will be displayed along with FF spread.	EGT↑ <i>1560</i> FFΔ <i>0.6</i>	Captured peak EGT value and the FF spread between richest and leanest cylinders.

LeanFind Procedure—General Explanation

Lycoming and Continental established specific restrictions on leaning that must be followed, such as percent power, climb leaning, and TIT limits. Lycoming recommends operation at peak of EGT at 75% or less power only. Continental recommends operation at peak EGT at 65% or less power only. This guide does not supersede specific recommendations of the engine or airframe manufacturer. **It is your responsibility to know your aircraft's limitations.**

Pre-leaning: The leaning process typically begins with 'pre-leaning' to insure all cylinders are operating rich of peak EGT (note: you can optionally activate 'Normalize' - hold LF until **NRM** appears - making it easier to confirm all EGT's decrease). Now enrichen the mixture to achieve a 50° drop on the hottest EGT. Insure that all EGT's decrease. Wait one minute to allow temperatures to stabilize.

Lean Find-Initiation: The leaning process typically begins with 'pre-leaning' to insure all cylinders are operating rich of peak EGT. This is accomplished as follows. As you lean the mixture watch the hottest EGT and note when it begins to decrease in temperature. Now enrichen the mixture to achieve a 50° drop on the hottest EGT. Insure that all EGT's decrease. Wait one minute to allow temperatures to stabilize. *Note: When the first EGT peaks, you can optionally activate 'Normalize' - hold LF until NRM appears - making it easier to confirm that all EGT's decrease.*

Lean Find-Initiation: Initiate the EDM leaning mode by tapping the **LF** button. *Note that the EDM displays its current leaning mode momentarily: 'ROP' for operating Rich of Peak or 'LOP' for operating Lean of Peak.* To change, simply hold **STEP** and **LF** until the display shows the other mode. The EDM is now waiting for a 15° rise on any EGT (this feature significantly reduces false peaks). Lean the mixture *without pausing* to achieve about a 10 deg per second change. With the vernier mixture control, turn the knob about a quarter turn every second. With the non-vernier or quadrant mixture control, lean slowly and smoothly about 1/16 inch every five seconds (note: leaning accurately with a quadrant system is difficult due to its mechanical linkage).

Lean Find-Activation: When a 15° EGT rise occurs, LeanFind activates (indicated by a cylinder I.D. box flashing over the number of the hottest EGT). **Remember: The LeanFind mode is not active until a cylinder I.D. box is flashing.** To show the progress of the leaning process, the EDM now displays the hottest EGT in the left side of the digital display and the fuel flow in the right side. This information allows you to observe the EGT behavior throughout the leaning process.

Lean Find-Rich Of Peak Detection: Eventually, one cylinder will reach peak before any of the other cylinders. The EDM will determine this automatically. The EDM will indicate success in finding a peak by displaying the word **LEANEST** for two seconds and flashing its corresponding Cylinder I.D. Box. The *Scanner*® Information Area will also display the current value for the peaked EGT on the left, and the fuel flow value on the right, for final adjustment of the mixture. The peak EGT value and FF value encountered during leaning is remembered by the EDM and can be displayed by holding the **PEAK** button during Lean Find Mode.

Lean Find-Finalizing the Rich Of Peak Mixture: You may now enrichen the mixture to operate at peak or continue enriching to a value of your choice (typically between 50 to 100° rich of peak for best power), consistent with the procedures defined in your aircraft and/or engine manual. Note: tap **PEAK** to see the current difference from the peak temperature. This is handy for finalizing mixture. Tapping **EXIT** exits the lean find mode and automatic scanning resumes.

Peak Detected - Rich Of Peak Mode

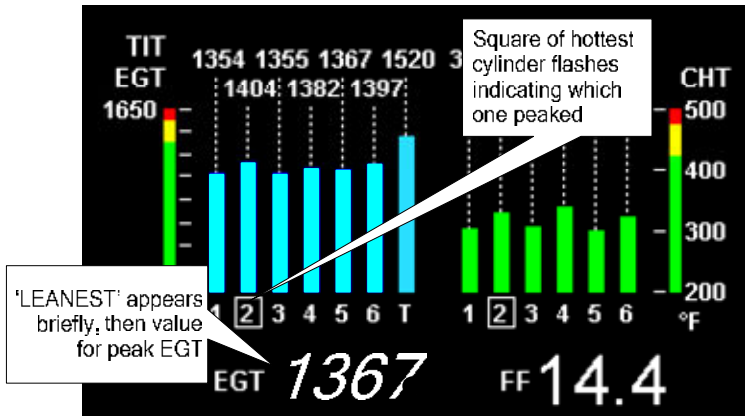

Lean Find-Lean Of Peak Detection: Note: This mode should only be used when your engine is equipped with balanced fuel injectors. When using the Lean of Peak mode, you lean until *all* EGT's decrease slightly below their respective peaks. The EDM has automatic peak detection and will sequentially indicate leaning progress. When the first EGT peaks, the word **LEANEST** appears and the cylinder I.D. box highlights the cylinder number. Each column successively drops as leaning continues. When the last column drops (last EGT peaks), **RICHEST** appears and its respective column flashes momentarily. The last EGT to peak is the one you will use when setting the final mixture.

Lean Find-Finalizing the Lean Of Peak Mixture: The *Scanner*® Information Area displays the degrees below peak for the **last** (or richest) EGT to peak, giving you precise information necessary in setting the final mixture. Adjust the mixture to achieve the desired value below peak (using the digital EGT readout) or before engine roughness occurs. Caution: do not lean to the point where the engine runs rough. Note: the peak EGT value encountered during leaning can be recalled by holding the PEAK button. Tapping STEP exits the lean find mode and automatic scanning resumes.

Peak Detected - Lean Of Peak Mode

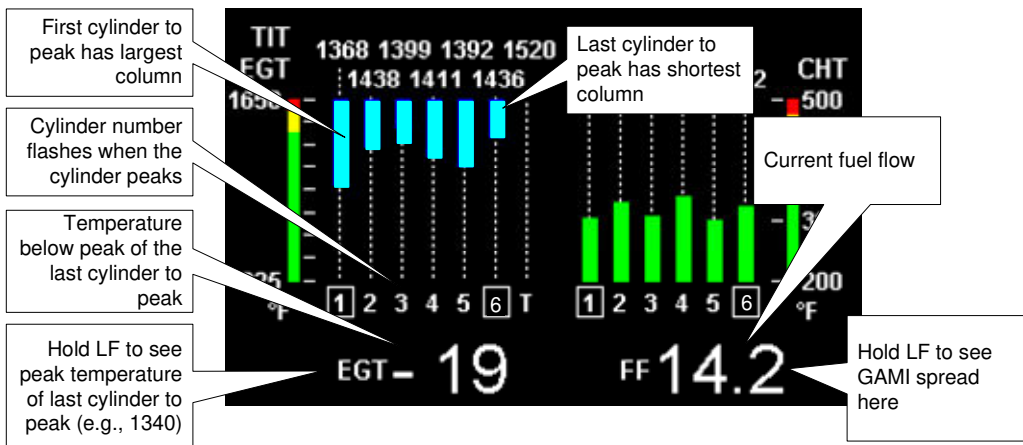

Expanded Leaning Procedures

Lean Of Peak mode: During the 'lean of peak' process, the EDM hunts for the last cylinder to peak. Ultimately, you want to have ALL cylinders operating on the lean side of peak. You will final adjust your mixture to this cylinder. To provide a unique graphical depiction during lean of peak operation, the columns become inverted after the first EGT goes just beyond peak. Each EGT column then originates from the top of the display and drops downward. As each subsequent EGT goes past peak, its column will begin falling. The columns length depicts how far the EGT has dropped below its original peak. In this mode, each segment is 5° F. You will continue to lean until the last EGT peaks note: never lean to the point where the engine is running rough). When the last EGT peaks, its column will flash and **RICHEST** appears. The digital readout will show the current temperature difference from where peak EGT occurred and the current fuel flow (if so equipped). Note: holding the PEAK button will show the captured peak value of the 'last EGT to peak' and also the difference in fuel flow between the first and last to peak (known as the GAMI Spread). This is a good indication of injector balance (the smaller the FF difference, the better the balance). Tapping STEP exits the lean find mode and automatic scanning resumes.

Leaning Turbocharged Engines: *The leaning process for turbocharged engines is by reference to the first EGT or TIT to reach peak. Therefore you should use the Rich Of Peak mode. The factory TIT red line (typically 1650°F to 1750°F) may limit the leaning process, depending on flight conditions. If TIT exceeds red line (but not by more than 99°), the EDM will allow you to continue leaning for one minute before a TIT alarm activates. NOTE: TIT can read approximately 100°F hotter than the hottest EGT due to unburned fuel in the exhaust igniting and is not necessarily abnormal behavior. The reduced size of the JPI Hastaloy-X-tip probes produce faster response and are more accurate than the massive factory installed probes. Therefore a JPI probe may read as much as 100°F higher than the factory installed probe. However, the certified factory-installed gauge must be obeyed as the limiting factor when adjusting your engine.*

Section 6 - Fuel Flow Operation

Fuel Management

Without a means of measuring accurate fuel flow, you must rely on the aircraft fuel gauges or total time of flight. Aircraft fuel gauges are notoriously inaccurate (they are only required by the FAA to read accurately when displaying *empty*). Determining fuel consumption by multiplying time of flight by estimated flow rate is, at best, an approximation, and assumes a constant fuel flow rate for each phase of flight. However, the EDM Fuel Flow Option uses a small, turbine transducer that measures the fuel flowing into the engine. Higher fuel flow causes the transducer turbine to rotate faster which generates a faster pulse rate. Because the transducer turbine generates thousands of pulses per gallon of fuel, it can measure with high resolution the amount of fuel that flows into the engine. Prior to engine start you inform the EDM Fuel Flow Computer system of the known quantity of fuel onboard, it then subsequently tracks all fuel delivered to the engine.

IMPORTANT !

For EDM fuel calculations to be accurate, it is mandatory that you inform the EDM of the correct amount of usable fuel onboard the aircraft and confirm proper operation of the fuel flow transducer prior to and during flight. Do not rely on fuel flow instruments to determine fuel levels in tanks. Refer to original fuel flow instrumentation for primary fuel management information.

Start Up Fuel

On power-up, you will be prompted to enter any fuel you might have added to the aircraft (this process updates the **REM** and **USD** values). The EDM will flash **REFUEL?**. If you didn't add any fuel, simply tap EXIT to quit, otherwise tap NEXT to pick one of the three quickset choices below:

- Choice 1) *MAIN 66.0 GAL* : Tap SAVE to accept or NEXT for choice #2. This shortcut sets **REM** to the MAIN tank value (66 in this case) you set up in your fuel computer.
- Choice 2) *MAIN + AUX 82.0 GAL* : Tap SAVE to accept or NEXT for choice #3. This shortcut sets **REM** to the sum of MAIN and AUX you set up in your fuel computer.
- Choice 3) *Adjust? + 0.0 GAL* : Tap either ADD or REMOVE to adjust **REM**. Use when adding a partial amount of fuel. Tap SAVE to accept adjustment or NEXT to repeat **REFUEL?**.

NOTE: If you forgot to perform your EDM REFUEL before starting the engine, it can still be performed. The EDM will automatically subtract any burned fuel from the value you choose (not applicable to the 'Adjust? + 0.0' feature)

You are responsible for insuring that your usage of the REFUEL feature results in the EDM's REM parameter showing the correct amount of usable fuel remaining onboard the aircraft.

The three examples, shown below, depict different aircraft tank configurations and how you can update your EDM after refueling your aircraft. These are meant to be general guidelines.

Example A: Aircraft has two fuel tanks with internal tabs.

You've preset: '**MAIN = 66'** (33 + 33 usable)

'**AUX = 16'** (8 + 8 usable)

When you refuel:

'**MAIN 66.0 GAL**': use this shortcut when filling to the internal tank tabs.

'**MAIN+AUX 82.0 GAL**': use this shortcut when filling to the caps.

(only one tank is shown in each of the two scenarios)

MAIN 66.0 GAL

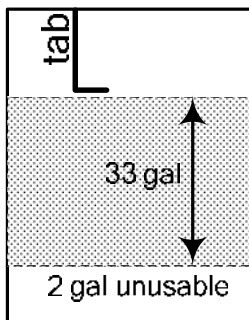

MAIN+AUX 82.0 GAL

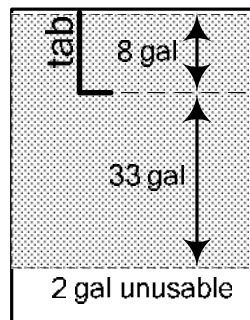

Example B: Aircraft has two MAIN and two AUX tanks.

You've preset: **'MAIN = 60'** (30 + 30 usable)

'AUX = 14' (7 + 7 usable)

When you refuel:

'MAIN 60 GAL': use this shortcut when filling only MAIN tanks
(! AUX tanks must be empty).

'MAIN+AUX 74 GAL': use this shortcut when filling MAIN and
AUX tanks.

(only one wing shown in each of the two scenarios)

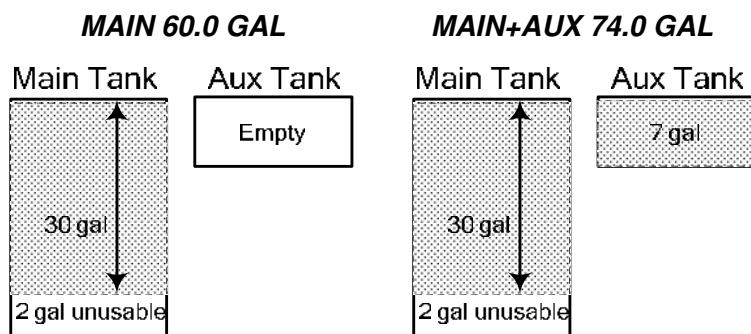

Example C: Aircraft has two MAIN tanks.

When you partially refuel, use:

‘Adjust? + 0.0 GAL’: use this to add the amount of fuel you pumped into the aircraft (it doesn’t matter which tanks you added to - the EDM totalizes ALL onboard usable fuel). In this example you will add **‘+ 14.0 GAL’**, the same as your fuel slip reads. This will be added to the totalizer REM value.

Adjust? + 14.0 GAL

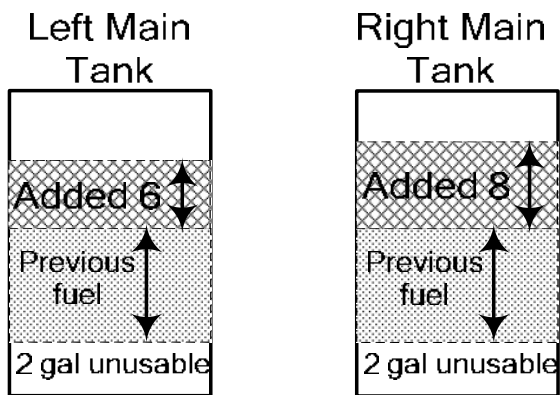

Resetting 'USD'

USD is automatically reset whenever you perform **REFUEL** on your EDM (except if TRIP mode = yes).

After filling your tanks and prior to engine start you should inform the EDM that the aircraft has been filled. In this case **USD** is automatically set to zero.

If you forgot and have already started the engine, and then you inform the EDM that tanks have been filled, then some fuel has already been used. Not to worry as the EDM will automatically set **USD** to this amount and also subtract it from the **REM** value, keeping the two values in balance.

To manually zero the amount of fuel USD at any time, manually STEP to display **USD** and then hold both DIM (button 3) and EGT/FF (button 4) until the display shows '**.0 USD**' (this normally takes about five seconds).

Trip Mode (Accumulate Trip Totalizer)

Trip mode is typically used if you want to track the total fuel used over a multi-stop cross country. To have the **USD** parameter continuously accumulate total consumed fuel, set **TRIP?** Y. 'Trip Mode' is described in the 'Program Mode section'. Note: typically, **TRIP?** is set to 'N' so that **USD** will be reset every time you fuel the aircraft.

Scanner Fuel Flow Display Select

Button four selects three different Scanner filters - ALL, EGT or FF. Tapping this button will select the next choice (shown after the '/' symbol):

- **ALL/EGT**: all installed parameters are shown in Scanner.
- **EGT/FF**: only the installed temperature (and battery voltage) parameters are shown in Scanner.
- **FF/ALL**: only fuel flow parameters are shown in Scanner.

Note: Scanner filter or mode selection does not affect Alarms or analog displays.

Section 7 - Alarms

Whenever a measured parameter falls outside of the normal allowed operating limits, i.e. goes beyond redline, the main display will blink an alert icon. This consists of the current digital value and a flashing red label in the Scanner area and the RAD. For example, if CHT 2 is at 480, and redline is 460, the alert would be displayed as *480 HI CHT2*. Other alarm examples are:

2780 HI RPM, 15 LO OIL-PSI, 240 HI OIL-TEMP.

Tapping the CLEAR button extinguishes the alert for ten minutes whereas holding the CLEAR button turns the alarm off for the remainder of the flight.

Primary alarm *limits* for each specific aircraft model are set by JPI in accordance with the Pilot Operating Handbook and/or TCDS and are not programmable by the pilot. These typically include some or all of the following measurements: CHT, CDT, O-T, O-P, F-P, GAL LEFT, GAL RIGHT, MAP, RPM, FF, IAT, CRB, and TIT. To view the alarm limits screen, hold button 2 during power up (or hold both buttons 2 & 3 during normal operation), tap NEXT until the list is displayed.

The primary functions for your installation are shown on the Primary label on the back of the instrument and are identical to those specified in the FAA Approved Airplane Flight Manual/Pilot's Operating Handbook.

Non-primary Alarm Priority

Primary alarms will always have precedence over non-primary alarms. The typical non-primary alarm priorities are as follows:

Highest.....Lowest

MIN → REM → DIF → CLD → BUS H → BUS L → AMP

Section 8 - Memory and Data Download

The EDM compresses and records **all** displayed parameters once every **six seconds (default)** in Long Term Data Memory (note: you can change this rate to be 2 to 500 seconds). This data is retrievable by inserting a USB Drive into the jack on the front of the instrument and following the prompts. You can choose to retrieve '*ALL*' the data stored in the EDM, or only the '*NEW*' data recorded since your last retrieval. In either case, the selected data in the EDM is not erased. The data can later be viewed on EZTrends, a PC program available from JPI or over the internet.

Recording typically begins when EGTs are greater than 500°F or RPM is greater than 500. The amount of data that the EDM can store will vary depending on how rapidly parameters change. The typical storage capacity is greater than 100 hours at a 6 second recording interval, but can vary depending on configuration. When the memory becomes full, the oldest data will be discarded to make room for the newest. All data are time-stamped. The EDM contains a real-time clock that may be set when you initially program your instrument. You may change the recording interval from 2 to 500 seconds, even in flight (when you change the interval in flight, the current flight file is closed and a new flight file is started at the new interval).

Downloading Data from the EDM

Downloading is a simple process. Follow the steps below:

- a. With the EDM powered up, plug the USB flash drive into the EDM USB port.
- b. Wait for the EDM display to show *DOWNLOAD: NEW*.
- c. To download only the new data since the last download, tap the **STEP** button.
- d. To download all data in the EDM, tap the **CHANGE** button to see *DOWNLOAD: ALL*, then tap **STEP**.
- e. You will see a 'progress indicator' as the data is copied to the USB flash drive. **DO NOT INTERRUPT THIS PROCESS.** When the download is complete the display on the EDM will show **DONE** and then return to normal operation.
- f. Wait until the process is complete then remove the USB flash drive from the USB connector.

Transferring data from the USB Flash Drive to a PC

To transfer your data from the USB flash drive to your PC, follow these easy steps.

1. On your PC, start the EzTrends program.
 2. Plug in the USB flash drive into an available USB port.
 3. In EzTrends, select the Move and Plot Data from Memory Stick option.
 4. In the displayed list, find the USB flash drive and double click it.
 5. Select the file you wish to plot and then select the flight in that file.
- Refer to the EzTrends manual for details on how to use EzTrends.

Section 9 - First Time Setup and Customization

Your EDM comes with most settings programmed. However some settings you will fine tune to your installation and/or preferences. We recommend you perform the following minimum set up:

1. Pilot Programming Mode:

- Set the GPS Communications format to match your type of GPS.
- Fine tuning of fuel flow K-factor is important as it affects your fuel computer parameter accuracies.
- Set the Engine HP equal to your engines rated horsepower.
- Perform the HP Constant set up for best accuracy of the Percent Horsepower readout.
- Optionally fine tune other parameters such as MAP, OAT.

2. EDM Screen Customization

Use 'EDM Config' to customize your EDM. All EDM930 and EDM960 units manufactured or updated after Sep 15, 2012 have the EDM Configuration Editor built into a separate utility memory area of the EDM.

To start the EDM Configuration Editor, hold the left two EDM buttons (STEP & LF) while powering up the EDM. This will start the EDM in a special **AppLoader** mode. Once the EDM Configuration Editor program is found, a button will be labeled **CFG EDITOR**. Press the button to run the EDM Configuration Editor program.

When EDM Configuration Editor starts, it will show a startup screen titled **EDM960 Configuration Editor** or **EDM930 Configuration Editor** that lists the version information for the Editor.

3. Fuel Level Calibration

- Fuel Level calibration must be performed before the fuel level feature will function.
- Collect your calibration data for various fuel tank levels (called points) by putting the EDM into the 'Fuel Level Readings' mode. Carefully review readings during the process to insure the

calibration data is sensible, correct and useable. *Note: Please refer to the installation manual for accessing fuel tables and calibration on page 22 item 24.4.*

- Enter the data by putting the EDM into 'Fuel Table Data' mode and enter your values into each tanks chart.

Pilot Programming Mode

To start Pilot Program Mode, hold both **STEP** and **LF** buttons until you see **PROGRAM** for two seconds. Then tap the **NEXT** button to advance to the desired item in the list. Hold the **NEXT** button to back up in the list. Either tap **NEXT** until you see **END? Yes** and then tap **EXIT** or hold both **NEXT** and **LF** to save changes.

<i>First button advances to NEXT item</i>	<i>Second button selects values</i>	<i>Comments</i>
Program Mode		Stays on for two seconds.
Refuel?		Tap REFUEL to change fuel status. Exits program mode when done.
Auto Scan Rate 4	0 ⇔ 9	Scan rate (seconds between parameters) in the Automatic Mode. 0 disables the Automatic Mode.
Trip Used? No	NO ⇔ YES	NO : When Refuel mode used on EDM, total fuel used is reset to 0. YES : accumulate total fuel used rather than reset to 0 at each refueling. See page 43
EGT Display in 1's	1's 10's	Tapping 1's sets the digital display to one-degree resolution; tapping 10's sets 10°. (10° resolution is easier to interpret the EGTs.)
OAT Display °F	F ⇔ C	Tap C to display OAT in Celsius, F to display in Fahrenheit. Hold STEP and LF for 5 seconds to ADJUST the OAT calibration.
OAT Adjustment 0	-10 ⇔ +10	Adjust the indicated temperature up or down by up to 10° using PLUS or MINUS . For example, OAT+3 adjust the OAT 3° higher.
HP Constants		Hold NEXT and button 2 for 5 seconds until you see ADJUST rich of peak or lean of peak constants. Tap ROP to proceed to Rich of Peak 'HP Constant' setting. Tap LOP to proceed to Lean of Peak 'Engine Constant' setting.

HP Constant= 125	10 ⇔ 999	Hold NEXT and button 2 until you see ADJUST . Tap PLUS or MINUS to adjust (%HP display will reflect changes). Hold NEXT and button 2 to save changes.
Engine Constant = 14.9	1 ⇔ 99.9	Hold NEXT and button until you see ADJUST . Tap PLUS or MINUS to adjust. Hold NEXT and button 2 to save changes.
Engine HP = 225	10⇔999	Set the nominal horsepower of your engine. This value will be multiplied by the %HP to display HP. Hold NEXT and button 2 for 5 seconds until you see ADJUST . Use PLUS or MINUS to adjust. Tap SAVE to save changes. Tap NEXT to skip to next item.
Map Adjustment +0.0	-3.0 ⇔ +3.0	Correct the MAP to the altimeter setting at a sea level airport ±3.0 inHg. Hold NEXT and button 2 for 5 seconds until you see ADJUST . Use PLUS or MINUS to adjust. Tap SAVE to save changes. Tap NEXT to skip to next item.
K-Factor 1 29.90	00.10 ⇔ 99.99	Set the instrument's K-factor to match the fuel flow transducer K-factor and performance. Hold DIGIT and button 2 for 5 seconds until you see ADJUST . Use DIGIT , PLUS or MINUS to adjust. Hold NEXT and button 2 to save changes.
GPS Format = 6	0 ⇔ 8	Adjust to set the GPS Communications format. Hold NEXT and button 2 for 5 seconds until you see ADJUST . Use PLUS or MINUS to adjust. Tap SAVE to save changes. Tap NEXT to skip to next item. See page 46.
Time: 18:23:59	00:00:00 ⇔ 23:59:59	Hold NEXT and button 2 for 5 seconds until you see ADJUST . Use Hours , Minutes , Seconds to adjust. Tap SAVE to save changes. Tap NEXT to skip to next item.
Date: 05/14/09	01/01/00 ⇔ 12/31/99	Hold NEXT and button 2 for 5 seconds until you see ADJUST . Use Month , Day , Year to adjust. Tap SAVE to save changes. Tap NEXT to skip to next item.
END? Yes	END? Yes	Yes exits the pilot program mode. No reenters pilot program mode.

Adjusting the HP Constant for Rich of Peak Operation

To fine tune the %HP readout, follow this procedure airborne between 5,000 and 8,000 feet MSL.

1. Enter the pilot program mode by simultaneously holding the STEP and LF buttons for five seconds.
2. Tap STEP repeatedly until you see **HP Constants**. Hold both NEXT and Button 2 until you see **ROP** and **LOP** appear in status bar. Tap **ROP**. Now **HP Constant 125** should appear. Hold both NEXT and Button 2 until you see **ADJUST** momentarily. Adjustment range for the HP Constant is 50 to 300.
3. Set the MP and RPM per your POH to 70 percent power. Let conditions stabilize.
4. Adjust the HP Constant value PLUS or MINUS so that the %HP reading on the display equals '**70 %HP**'. Note: this is the percent of maximum horsepower.
5. Hold both NEXT and Button 2 until you see **SET**.

Adjusting the MAP

This procedure allows you to adjust the MAP to the altimeter setting at a sea level airport. **NOTE: If airport is not at sea level, use the correction table to derive corrected sea level altimeter setting).**

1. Enter the pilot program mode by simultaneously holding the STEP and LF buttons for five seconds.
2. Tap NEXT repeatedly until you see **MAP ADJUSTMENT +0.0**. Then hold both the NEXT and Button 2 until you see **ADJUST** momentarily.
3. Adjust the value using the PLUS or MINUS until the value equals the altimeter setting (sea level airport). The adjustment range for the MAP is ± 3.0 inHg.
4. Hold both NEXT and Button 2 until you see **SET**.

Adjusting the HP Value

You must set the nominal horsepower of your engine. This value is used to calculate the percent horsepower display.

1. Enter the pilot program mode by simultaneously holding the STEP and LF buttons for five seconds.
2. Tap NEXT repeatedly until you see **Engine HP 200**. Then hold both the NEXT and Button 2 until you see **ADJUST** momentarily.
3. Adjust the value PLUS or MINUS to equal your engines HP.
4. Hold both NEXT and Button 2 until you see **SET**.

Fuel Flow K factor

The K factor is shown on the fuel flow transducer as a hand written four-digit number, which represents the number of pulses per tenth gallon of fuel flow. **Before installing the transducer, record its K factor here _____**. The EDM stores the K Factor in the form **29.12**, i.e. if the transducer K factor is 2912, you would enter 29.12 in the EDM's K factor field.

Fine Tuning the K factor

The K factor shown on the fuel flow transducer does not take into account your aircraft's particular installation. Fuel hose diameters and lengths, elbows, fittings and routing can cause the true K factor to be different from that shown on the fuel flow transducer. Fine tuning is accomplished over multiple flights of sufficient duration and repeatable conditions. Use the process below to calculate and correct the K Factor to achieve maximum performance. Note: This process adjusts the K factor only half of the correction. We recommend this because it minimizes 'chasing' a correction target back and forth.

1. Record data for three flights of about two to three hours each. Record the actual fuel used for each flight (total pumped to top the tanks) and the EDM **USD** value prior to shutting down after the flight.

<i>Flight</i>	EDM ' USD '	ACTUAL USED (Total pumped to top used tanks)
A		
B		
C		
Totals	①	②

2. Add up all flight amounts for each column and post Totals in locations **①** and **②**.

3. Record the EDM's current K factor here **③** _____ and in the table below.

4. Calculate the Adjustment ratio:

$$\text{Adjustment ratio} = \frac{(\text{①} / \text{②}) - 1}{2}$$

5. New K Factor = **③** x (Adjustment ratio + 1).

Record the values here:

<i>Date</i>	① EDM <i>fuel used</i>	② actual <i>fuel used</i>	③ Current K <i>factor</i>	<i>New K factor</i>	<i>Pilot's initials</i>

Entering the K factor

This process is used to enter/modify the K factor value in the EDM.

1. Enter the pilot program mode by simultaneously holding the STEP and LF buttons for five seconds until you see **PROGRAM MODE**.
2. Tap NEXT repeatedly until you see **K-Factor 1 29.90** .
3. Hold DIGIT and Button 2 until the first digit flashes (shown here as bolder digit for illustration purposes): **29.90**
4. Tap DIGIT to move to the desired digit.
5. Adjust the digits value using PLUS or MINUS as desired.
6. Repeat items 4 and 5 for the remaining digits.
7. Hold both NEXT and Button 2 until you see **SET**.

If the K factor is increased, the indicated fuel flow will decrease, and vice-versa. *NOTE: When the K factor is changed during a trip, calculations of fuel used, fuel remaining and time to empty are not retroactively recalculated.*

Programming Trip Mode

Trip Mode keeps a running total of fuel used (USD) for all flights. If Trip Mode = No, fuel 'USD' is zeroed after updating the EDM's fuel computer via **Refuel** modes. *NOTE: to clear the fuel used display at any time, tap STEP until you see USD. Hold both DIM and ALL/EGT/FF buttons until the display shows '.0 USD'.*

1. Enter the pilot program mode by simultaneously holding the STEP and LF buttons for five seconds.
2. Tap NEXT repeatedly until you see **TRIP Used? No** .
3. Tap YES to select the trip mode or NO to deselect mode.
4. Tap NEXT to accept your choice.

Setting the GPS Com Format

This process allows you to select what GPS communication format the EDM should use when sending fuel flow data to the GPS. See table below with the numeric GPS-C values and their corresponding formats.

1. Enter the pilot program mode by simultaneously holding the STEP and LF buttons for five seconds.
2. Tap NEXT repeatedly until you see **GPS FORMAT** .
3. Hold DIGIT and Button 2 until **ADJUST** appears
4. Select desired code value using PLUS or MINUS.
5. Hold both NEXT and Button 2 until you see **SET**.

<i>GPS-C</i>	<i>Type of GPS Format</i>
0	No fuel data output
1	Garmin (Shadin Miniflow format)
2	Allied Signal (format B) "To waypoint only"
4	Arnav/EI fuel flow data
4	Allied Signal (format C) *
5	(Not used)
6	Garmin 430/530 GNX-80/GX-60 "To waypoint only"
7	Garmin 430/530 GNX-80/GX-60 "To Destination only"
8	Bendix(B) - DEST

Section 10 - Custom Key Card

The EDM contains a Key Card which customizes it for your aircraft. **This card defines fixed primary instrument limits and ranges, EDM serial number and make, model and year of your aircraft. You cannot exchange it with any other EDM.** Typical parameters include: oil temp, oil pressure, fuel pressure, fuel quantity, cylinder head temp, turbine inlet temp, manifold pressure, and RPM. Do not remove the Key Card from the instrument. If your EDM should ever have to be replaced with a different unit, the factory will reprogram your Key Card to match the new serial number. Always confirm that your aircraft make and model are initially shown in the RAD upon power up.

Section 11 - Setting Fuel Calibration Points

WARNING:

- ! Never add or remove fuel from the aircraft when the master switch is turned on.**
- ! Fuel quantity gauge performance is affected by many factors, such as the integrity of the sensor performance, the accuracy of the calibration data you collected and entered and most importantly your validation that the EDM fuel quantity gauge is accurate and repeatable after installation and calibration. You should not use the fuel quantity gauge system for any flight related operations until this validation criteria has been met.**

The EDM interfaces to various fuel level sensor types to facilitate direct reading of the fuel level in the aircraft fuel tanks. The EDM has a multi-point fuel calibration table that you must enter. This table contains calibration values (stored in non-volatile memory) used to translate sensor readings into the displayed fuel quantity values. The calibration information is collected and recorded on paper for later entry into the EDM. NOTE: Fuel quantity gauges will not be functional until the fuel calibration information has been entered into the EDM. You will use the EDM instrument itself as the measuring device to collect calibration data. Refer to Installation Manual Report 908 for expanded information on fuel level system implementation.

The following describes the basic procedures necessary for collection and entry of data into the fuel level calibration table. Note: Any changes to fuel table data will be temporary until you execute the '**SAVE**' function (available after last cell of the last tank table is entered).

Before beginning the fuel table entry/edit process, you must have properly installed and tested for correct functionality of the fuel sensors.

Capturing the sender reading at each calibration point:

Getting Started...Collecting Fuel Level Calibration Data using the EDM as a meter.

1. With power off, hold in **Button 4 (Button 1 being far left)** and then turn on power. For each EDM monitored tank, create a **paper table** with the desired number of calibration points (2 to 5) and at what volume each will be. Number of calibration points to be entered into the system later. The zero gallon point reading is always taken with unusable fuel in the tank. Example of a completed 3 point table for **LEFT** tank:

LEFT	
F 39.0 GAL	1907
2 19.5 GAL	1154
E 0.0 GAL	685

Readings

2. This screen provides real-time readings of all active fuel level sensors. Verify readings look normal. Reading are arbitrary whole numbers
3. Now add fuel as needed to match the required volume for a particular point. Allow this to settle, then take a reading and record it on paper adjacent to that point.
4. Repeat this process until all points, 2 to 5, have been recorded for each tank.



After you have collected your data

After you have collected your data...Entering / Editing Fuel Level Calibration Data

The Fuel Table Editor is a spreadsheet type format allowing you to easily see the volume and related calibration values side by side. You can easily navigate through the cells to enter values.

1. With power off, hold in **Button 3 (Button 1 being far left)** and then turn on power. Wait until you see '**Do you agree with the disclaimer?**'. Tap **YES** if you agree and wish to continue.

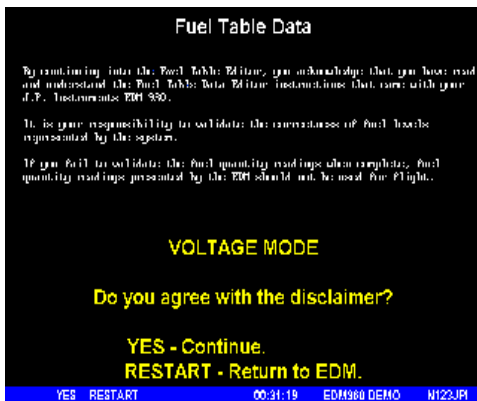

2. Tap **YES** when you see '**Do you have table data?**'.

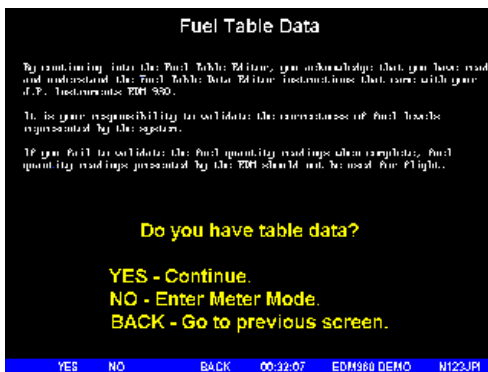

3. Tap **USER** when you see **'Do you want to restore user table?'**
Note: tapping **FACTORY** causes the fuel table stored on the Key Card to over-write any previous user entries in the fuel table. Use **FACTORY** if you want to start from the original factory default.

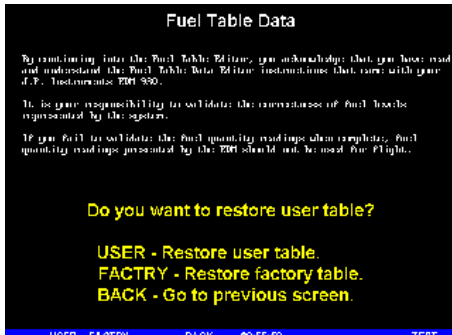

4. Tap **POINTS** when you see **'Do you want to edit the table?'**.

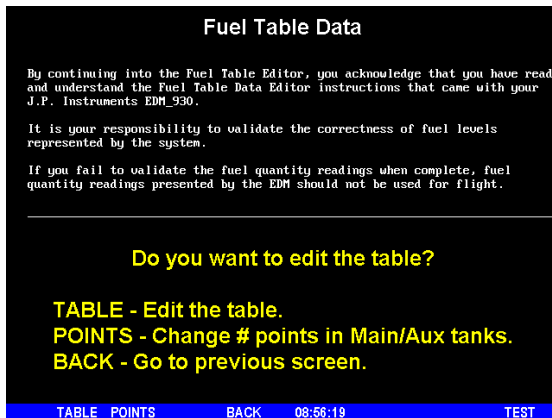

- You see '**Points in LEFT**', the current calibration points for the LEFT tank.

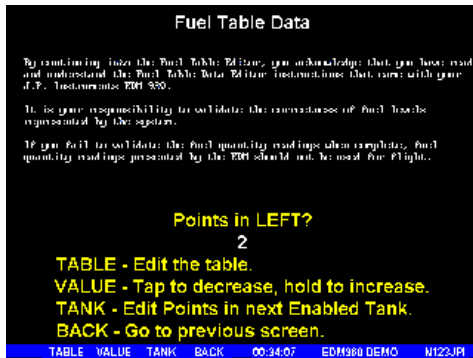

- Tap/hold **VALUE** to change to the desired number of calibration points for this tank (2 to 5). Each Tank can have a different set of calibration points. So 5 points for Main and 2 points for Aux.
- Tap **TANK** to select the next active tank and repeat previous step. Continue until all tanks 'points' have been set.
- Tap **TABLE**. You see '**Fuel Table Data**' (White at top of screen) with a table.

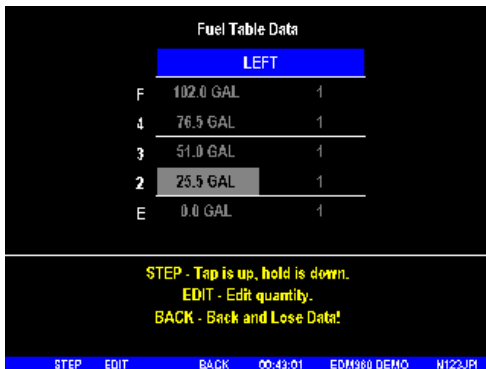

9. Tap/hold **STEP** to select the cell you want to edit. Tap **EDIT** to change the value. Tap **SAVE** to record it. Follow the on-screen menus to edit the value. Keep tapping **DIGIT** to move it across.
10. Repeat previous step until all tanks data have been entered.
11. You see '**Save fuel tank data?**'. Answer **SAVE** to store all final data values or **CANCEL** to return to table editing.

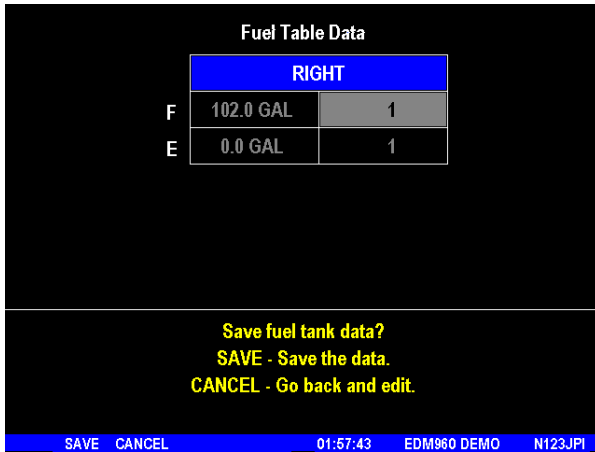

Troubleshooting the EDM

Common Misapplications

<i>Problem</i>	<i>Situation</i>	<i>Correction</i>
Display freezes or may be incorrect	A power transient could cause the processors to malfunction	Recycle the power to the EDM
LeanFind finds a “peak” too soon	Failure to pre-lean before performing LeanFind or stopping while leaning	Continue to lean without stopping
	Leaning too slowly	Lean more rapidly
Peak not found during LeanFind	Lean Find not activated or stopping while leaning	Lean at the speed of approximately 10°F per second
Off-scale EGT columns, too high or low	Off-scale EGT column readings. EDM in the Normalize view (blue scales)	The higher sensitivity of the Normalize view can quickly go too high or low off-scale with only small changes in EGT.
First cylinder to peak is not the hottest	This is normal. The first to cylinder peak is not necessarily the hottest	
EGTs rise during single magneto check	This is normal, due to incomplete combustion persisting longer	
EGTs not uniform during low power operation	This is normal. Fuel and air distribution is not optimal at low power settings	

Diagnostic Testing on Startup and During Flight

When your EDM is first turned on it tests internal components, calibration and integrity of the probes. Most alarms are disabled until the engine has been started.

During flight, probes are constantly checked for inconsistent or intermittent signals. A faulty channel or probe encountered during start-up or during flight will be deleted from the sequence, producing a missing column or blank digital data.

Diagnostic Messages

The following displays indicate malfunctions in the system:

Startup and Operational Diagnostics

0.0 GPH	Zero's indicate Fuel flow is too low to register
--- GPH	Dashes indicate No fuel flow transducer signals
--- H.M	Dashes indicate No fuel flow transducer signals
OPEN PRB	Open probe. Wiring to probe is open circuit. Check wiring and crimps. Swap probes to troubleshoot.
BAD-PRB	Bad probe. Erratic reading. May be poor electrical connection. Swap probes to troubleshoot.
Red 'X' drawn through a single gauge	Measurement out of range.
Red 'X' drawn through all gauges for an engine	DAU failure or DAU communications error. Check power to DAU and wiring harness connections.
CAL ERR	Calibration error. Return unit to factory.
DSP XXX	Internal communication error. Return unit to factory.
COMM ERR	Internal communication error. Return unit to factory.
NO 15 MV	Calibration error. Return unit to factory.
NO 50MV	Calibration error. Return unit to factory.
NO 2.5V	Calibration error. Return unit to factory.
PWR DWN	Power down the instrument and power up again.
WARNCAL, WARNCFG	Transient warning messages. If they persistently occur, return the unit to JPI for repair.
HOBSERR	The time of the most recent flight may not be reflected in the HOBBS meter.
HOBSBAD	The HOBBS data has been corrupted. The HOBBS meter will be cleared.
HANGCFG, HANGCAL	Internal system errors. Return unit to factory.

GPS Interface Diagnostics

Measurements 'xxx REQ', 'xxx RES' and 'xxx MPG' are all missing from the scan.	No communications from GPS receiver to EDM. Possibly no connection or aircraft GPS is off.
NO - COM message and 'xxx REQ', 'xxx RES' and 'xxx MPG' are all missing from the scan.	Communications are received by EDM and the Auto-Protocol setup is in process. Verify correct output format setup in GPS receiver; check GPS connections.
NO - SIG message and 'xxx REQ', 'xxx RES' and 'xxx MPG' are all missing from the scan.	GPS receiver has insufficient signal for valid data.
NO - WPT message and 'xxx REQ', 'xxx RES' are all missing from the scan.	No waypoints are programmed into the aircraft GPS receiver.
Message '- - - REQ' or '- - - RES' appears.	Your ground track is too many degrees (typically more than $\pm 70^\circ$) off from your course to the next GPS waypoint.

Section 12 - Appendices

TSO-only differences from Primary Instruments

TSO-only models have the following differences from the Primary models.

- If multiple alarms occur simultaneously, the higher priority alarm will temporarily “mask” the lower priority alarm(s). When an alarm occurs, tap the Clear button to clear the alarm indication so that you will be notified of any other alarm that might have occurred. The alarm priorities are as follows:

Highest priority	CHT	High CHT
	O-T	High OIL temperature
	O-P	Low oil pressure
	F-P	Low fuel pressure
	TIT	High TIT
	TK-LOW	Fuel tank low
	MIN	Low fuel endurance remaining
	REM	Low fuel quantity remaining
	F-P	High fuel pressure
	EGT	High EGT
	MAP	Overboost Manifold pressure
	DIF	Excessive EGT span
	CLD	Excessive CHT cooling rate
	RPM	RPM over redline
	O-T	Low oil temperature
	BUS	High battery voltage
	BUS	Low battery voltage
O-P	High oil pressure	
AMP	Amps discharge	
Lowest priority	BAL	Fuel level out of balance

- Aircraft make and model will not be shown in the RAD upon power up and will not be continuously shown on the bottom of the display window.
- The user can change factory set ranges and alarm limits.
- The Key Card is *not* programmed with the make, model and year of your aircraft.
- RAD alarm displays will be cleared and disabled along with the alarms displayed in the Scanner section.

- JPI Hastaloy-X probes may read as much as 100°F higher than the factory installed TIT probe. However, note that the engine was certified with the factory-installed TIT probe and gauge, and this gauge reading is the limiting factor when adjusting your engine.
- The user can assign the nine graphs in the bar graphs section to the desired measurements .
- Most measurements can be excluded from the *Automatic mode*.

Shock Cooling

Cooling the cylinders too fast can result in cracking and eventual failure. Lycoming Service Instruction 1094D (March 25, 1994) on ***Fuel Mixture Leaning Procedures states:***

“At all times, caution must be taken not to shock cool the cylinders. The maximum recommended temperature change should not exceed 50°F per minute.”

JPI checks shock cooling on all cylinders displaying the highest reading cylinder.

Rear Apron Connector Locations

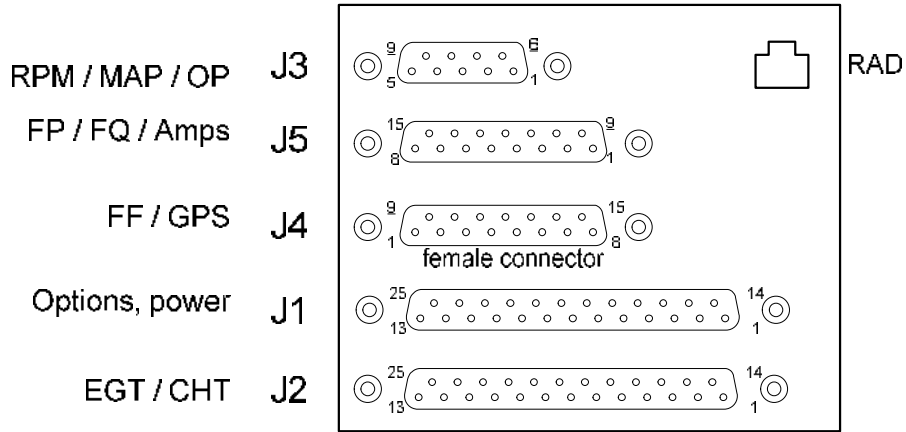

Connector pin assignments

P1 (for 4 / 6 cyl engine)		
Pin #		Function
yel 1	red 2	OIL T
yel 3	red 4	IAT
yel 5	red 6	CARB T
yel 14	red 15	OAT
yel 16	red 17	TIT 1
yel 18	red 19	TIT 2
	gry 12	rem V/T alarm
	red 13	+ Power
	wht 11	data in
	wht 24	data out
	blk 25	gnd to engine

P2 (EGT , CHT)		
Pin #		Function
yel 1	red 2	CHT 1
yel 3	red 4	CHT 2
yel 5	red 6	CHT 3
yel 7	red 8	CHT 4
yel 9	red 10	CHT 5
yel 11	red 12	CHT 6
yel 14	red 15	EGT 1
yel 16	red 17	EGT 2
yel 18	red 19	EGT 3
yel 20	red 21	EGT 4
yel 22	red 23	EGT 5
yel 24	red 25	EGT 6

P5 (FP, FQTY, AMPS)	
Pin #	Function
1	FQ 1 volt sig
2	FQ 1 volt sig
3	FQ gnd
4	FP sig+ (grn)
5	FP sig- (wht)
6	FP pwr (red)
7	FP gnd (blk)
9	FQ 1 freq sig
10	FQ 2 freq sig
11	FQ 1 pwr
12	FQ 2 pwr
13	Secondary +Power

P3 (MAP, RPM, OIL-P)	
Pin #	Function
grn 1	RPM sig (1)
blk 2	RPM gnd (2)
red 3	RPM pwr (3)
red 4	MAP pwr (3)
blk 5	MAP gnd (1)
wht 6	OIL-P sig (no pol)
blk 7	OIL-P sig (no pol)
wht 8	MAP sig+ (2)
grn 9	MAP sig- (4)

P4 (Fuel Flow, GPS)	
Pin #	Function
wht 1	out to GPS
gry 2	in from GPS
3	(nc)
wht 4	FF sig
red 5	FF power
blk 6	FF gnd
10	R tank low switch input
11	remote FF alarm
12	FF2 sig
13	L tank low switch input

P1 (for 7 / 8 / 9 cyl engine)		
Pin #		Function
yel 1	red 2	OIL T
yel 3	red 4	CARB T
yel 5	red 6	CHT 7
yel 7	red 8	CHT 8
yel 9	red 10	CHT 9
yel 14	red 15	OAT
yel 16	red 17	TIT 1
yel 18	red 19	EGT 7
yel 20	red 21	EGT 8
yel 22	red 23	EGT 9
	gry 12	rem V/T alarm
	red 13	+ Power
	wht 11	data in
	wht 24	data out
	blk 25	gnd to engine

Navigation Data Formats

Output of GPS; input to EDM. The EDM automatically configures itself for one of three industry standard data formats:

<i>Format</i>	<i>Baud</i>	
NMEA-183 (Marine Nav Data Format)	4,800	This is the format for most handheld GPS receivers. Loran must have sentences RMA & RMB. GPS must have sentences RMB & RMC.
Aviation Data Format	9,600	"Output sentence type 1" Required sentences are: A, B, C, D, E, I and L first character identifier byte. Sentence terminator may be either <CR><LF> or <CR> alone.
Northstar (Northstar binary)	1,200	M1 setup select "NO EXTENDED", "NAV ONLY"

Navigation Data Ports for GPS Comm

(These ports are independent of the EDM serial data output port.)

Navigation Data (output from GPS; input to EDM)

Compatible with RS-232, TTL, RS-423, RS-422 SDA.

Serial format: 8 data, 1 start, no parity. Baud 1200, 4800, or 9600, depending on the GPS data output format. The EDM automatically detects the GPS data output format and is independent of the GPS-C setting.

Fuel Data (input to GPS; output from EDM)

RS-232 Serial format: 8 data, 1 start, no parity. Baud 9600. Output format is determined by the GPS-C setting, but may be over-ridden by the GPS navigation format: If the EDM senses Northstar or NMEA-183 navigation data input, there will be no fuel data output.

Interface connections to selected GPS models

	EDM P4 - Pin 1 to:	EDM P4 - Pin 2 to:
Arnav 5000	Pin 4	Pin 5
Garmin 195	(nc)	Pin 4
Garmin 430 / 430	Pin 57	Pin 56
Northstar M3P	(nc)	Pin 6 (leave pin 11 open)
UPS GX50 / 60	Pin 4	Pin 5

Section 13 - Technical Support

JPI offers both e-mail and telephone technical support. Have your model and serial number ready when you call. Call **JPI** for a return authorization number before returning any equipment.

J.P.INSTRUMENTS Inc.

3185 B Airway

Costa Mesa, CA 92626

Call: (800) 345-4574

Web: www.jp instruments.com or www.JPITech.com

Limited Warranty

J.P. Instruments Inc. (JPI) warrants all parts in your new EDM to be free from defects in material and workmanship under normal use. Our obligation under this warranty is limited to overhaul or exchange of any defective part of this unit if the part is returned, shipping prepaid, within three years for electronics and one year for probes from the date of original purchase. Installation labor is the responsibility of the aircraft owner. Homebuilt aircraft warranty starts when the aircraft is certified for flight. Replacement parts carry a warranty for the balance of the warranty period.

Under this warranty, JPI is not responsible for any service charges, including removal, installation, nor any other consequential damages. JPI incurs no obligation under this warranty unless a Warranty Registration Certificate describing the warranted product has been completed and mailed to JPI with all information requested.

This warranty is void on any product which has been subject to misuse, accident, damage caused by negligence, damage in transit, handling or modification which, in the opinion of JPI, has been altered or repaired in any way that effects the reliability or detracts from the performance of the product, or any product whereon the serial number has been altered, defaced, effaced or destroyed.

This warranty is in lieu of all other warranties expressed or implied and other obligations of liability on JPI's part, and it neither assumes nor authorizes any other person to assume for JPI any other liability in connection with the sale of JPI products.

To initiate this warranty, the aircraft owner must submit a completed Data Logging Worksheet to JPI. Upon receiving a completed worksheet, JPI will initiate the warranty from the date of original purchase. Any replacement parts carry a warranty that extends for the balance of the period of the original warranty. For homebuilt aircraft the warranty starts when the aircraft is certificated for flight and noted on the warranty card.

Index

*

* *Pre-leaning procedure*., 22

A

Accumulate, 41
 total, 31
Alarm
 priority, 32
Alarm limits, 3, 32
 display, 11
Alarms, 32
Alerts, 32
Allied Signal, 42
Automatic mode, 16
Aviation data format, 53

B

BAL, 49
Bar graph, 3, 14
 column resolution, 12
Baud rate, 53
Blinking display, 20, 21, 25
Button
 DIM, 11
 LF, 11
 RoP/LoP, 11
Buttons
 front panel, 2, 10

C

Calibration
 fuel level, 43
 horsepower, 38, 39
 internal self test, 46
 K factor, 39
 MAP, 38
 OAT, 36
Carburetor

 ice, 8
 temperature, 17
Celsius
 display indicator, 13
 OAT, 36
Change
 button, 11
CHT
 too high or too low, 9
Climb, 6
Compression, 9
 low, 8
Compressor discharge temperature,
 CDT, 17
Connector
 pin assignments, 51
Cowling, obstruction, 9
Cruise, 6

D

Data
 GPS formats, 53
 ports, GPS, 53
Delete measurements, 16
Descent, 6
Detonation, 8, 9
Diagnostic
 fuel flow messages, 47
 GPS interface messages, 48
 self test, 46
DIF, 17
DIM, 11
Display, 12
 digital, 12
 flashing, 20, 21, 25
 Scanner, 12
Downloading, 33

E

EGT
 loss, 8
 resolution, display, 36

- select switch, 31
- too high, 8, 46
- too low, 8, 46
- Eliminate measurements, 16
- Engine
 - diagnosis chart, 8
 - limits, normal, 7
 - run-up, 5
- Error messages, 46
- Exclude measurements, 16
- Exhaust leak, 9
- EzConfig, 35

F

- Fahrenheit
 - display indicator, 13
 - OAT, 36
- Failure to pre-lean, 46
- Features, 5
- FF, select switch**, 31
- First cylinder to peak, 22
- First time setup, 35
- Flashing display, 20, 21, 25
- Flat EGT response, 8, 9
- Fuel
 - accumulate, 31
 - injectors, 9
 - injectors, clogged, 6, 8
 - Octane, 9
 - pump, 9
 - remaining, 17
 - required, 17
 - reserve, 17
 - start up, 2, 27
 - used, 17
- Fuel flow, 26
 - connector, 51
 - diagnostics messages**, 47
- Fuel level
 - calibration, 43
- Full throttle, 6

G

- GAMI, 18, 25
- Gasket, manifold, 9
- Getting started, 1

- GPS**
 - data formats**, 53
 - data ports**, 53
 - interface diagnostics**, 48

H

- H.S., 17
- Hastaloy**, 25, 50
- History
 - display, 59
- Hobbs, 11
 - display, 15
- Holding a button, 2, 10
- Horsepower
 - calibration, 39
 - constant setting, 38

I

- Ice, carburetor or induction, 8
- Ignition, 9
 - timing, 8
- Include measurements, 16
- Indexing
 - scan rate, 36
- Induction, 8
 - air temperature, IAT, 17
- Informing the EDM-930*
 - startup fuel, 27
- Intake valve, 8
- Interpreting
 - data, 5
 - display, 8

K

- K factor**
 - calibration**, 41
- Key card, 1, 42
- K-factor
 - calibration, 39

L

- Leak
 - manifold, 9

Leanest cylinder, 20, 21
LeanFind
 button, 11
 procedure, 4, 18

Leaning

by TIT, 25
 too quickly, 46
LF. See LeanFind
Long Term Memory
 operation, 33

M

Manual mode, 17

MAP
 calibration, 37, 38
 display, 3, 12

Miles per gallon, 17

Misapplications, 46

Missing
 column, 8

Mixture, 22

MPG, MPK, MPL, MPP, 17

N

Nautical miles per gallon, 17

Navigation data formats, 53

NMEA-183, 53

NO COM, 48

NO SIG, 48

NO WPT, 48

Normal engine limits, 7

Normalize view, 13

Northstar binary format, 53

NRM, 13

O

OAT

 calibration, 36

 F or C, 36

Octane, 9

Off-scale EGT bars, 46

OPEN PRB, 47

Operation, 10, 16

 fuel flow monitor, 26

P

Peak EGT, 22

PEAK EGT, 20, 21, 23

Pin assignments
 connectors, 51

Primary, 1
 preset alarm limits, 1, 42

Priority
 alarm, 32

Product support, 54

R

RAD, 1, 3, 15

Range, normal temperature, 7

Rate
 baud, 53
 fuel flow, 26
 indexing, 36
 shock cooling, 6

Recording. See Long Term Memory

Red line, 7

REM, 17

Remote Auxiliary Display. *See* RAD

Remove measurements, 16

REQ, 17

RES, 17

Resolution, EGT display, 36

Rich of Peak, 18

RoP/LoP
 button, 11

Rough engine, 8

RPM
 display, 3, 12

RS-232, 53

Run-up, 5

S

Scanner

 displays, 12

Scanner®, 4

Select switch, 31

Setup, 35

Shadin Miniflow, 42

Shock cooling, 6, 7, 17, 50

Spark plug

fouling, 5, 8
Standard view, 13
Startup
 diagnostics, 46
 fuel, 2, 27
Stuck valve, 8
Switch, select, 31

T

Tachometer. *See* RPM
Take-off, 6
Tapping a button, 2, 10
Technical support, 54
Test, self, 46
Time to empty, 17
Timing, ignition, 8
TIT, 25
Toggle, N, P, 13
Total
 fuel used, 17, 41
Total fuel, 31
Transducer, fuel flow, 26
Trip total, 41
Troubleshooting
 engine, 8

GPS, 48
instrument, 46
Troubleshooting
 fuel flow, 47
TSO-only models, 49
Turbocharged Engines, 25

U

Uniform, CHT, EGT not, 8
USD, 17

V

Valve
 lifter, 8
 stuck, 8
Vapor, 9
View
 change diagram, 11
 normalize, Standard, 13

W

Warranty, 54

QUICK REFERENCE

Automatic Scan

1. Tap LF.
2. Tap STEP.

Exclude Measurement in Automatic Scan (toggle)

1. Tap STEP to index to the measurement to exclude.
2. Tap both STEP and LF to toggle exclude/include status.
3. Decimal point before measurement name means it is excluded from scan.

Change Scan Indexing Rate

1. Hold STEP and LF until the display shows PROGRAM, followed by Refuel ?.
2. Tap NEXT, see Auto Scan Rate x .
3. Tap PLUS or MINUS to change the seconds per scan: 0 to 9.
Note: 0 disables auto scanning.
4. Tap NEXT until you see End?Yes, then EXIT to accept and exit.

Reset USD (Fuel Used)

1. Tap STEP until x USD shown.
2. Hold both DIM and EGT/FF until .0 USD is shown.

Display Hobbs

1. Hold the LF and DIM buttons simultaneously.

Download Data in Memory

1. Insert USB Flash Drive into front USB port on EDM.
2. *DOWNLOAD: NEW* (latest flight) or tap CHANGE to see *DOWNLOAD: ALL* (all stored flights).
3. Tap STEP and wait until download progress bar completes and normal display returns.
4. Remove USB Flash Drive.

Trip Mode (Accumulate Fuel Used)

1. Hold both STEP and LF until the display shows PROGRAM, followed by Refuel ?.
2. Tap NEXT until you see Trip Used? No .
3. To accumulate all fuel used, tap Yes and see TRIP? Y.
4. Tap left button until you see End ?Y and tap Yes to exit.

QUICK REFERENCE

Refueled the Aircraft

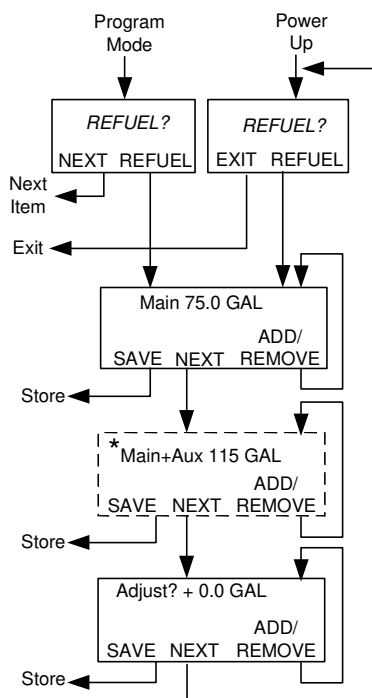

* If no aux tank is set up, then this step is skipped.

Reset Alarm

- **Temporary reset** (next 10 minutes): tap STEP.
- **Reset for remainder of flight:** hold STEP until the words Alarm Off appears.

Leaning Rich of Peak

1. Pre-lean & wait 20 seconds.
2. Tap LF & see ROP.
3. Lean until LEANEST flashes, then EGT 1485 FF 12.7 appear.
4. Tap LF to see degrees lean of peak: EGT- 23 FF 12.7
5. Enrich back to rich side of peak, then set desired degrees rich of peak: EGT- 41 FF 13.9
6. If desired, hold LF to see temp & FF when peak occurred: EGT 1534 FF 13.2
7. Tap EXIT to return to normal operation.

Leaning Lean of Peak

1. Pre-lean then wait 20 seconds.
2. Tap LF (if you see ROP, then hold STEP & LF until LOP appears).
3. Lean mixture noting that inverted columns appear.
4. Continue leaning until RICHEST flashes then EGT -73 FF 10.4 appear.
5. Adjust mixture to desired degrees lean of peak: EGT- 54 FF 10.9
6. If desired, hold LF to see the peak EGT of first cylinder to peak and the delta fuel flow (GAMI spread): EGT 1560 FF 1.0
7. Tap EXIT to return to normal operation.

NOTE: Values shown are examples and may vary for your aircraft